

EN

BEAM

Vacuum & Ventilation

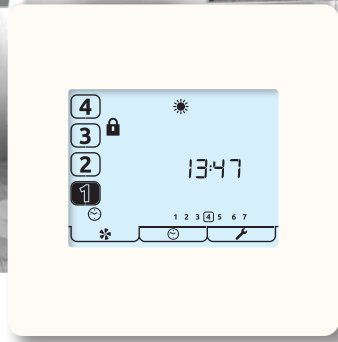

Owners Manual

aura-t

TP536/BEAM

axco MVHR controller



Warnings, Safety information and Guidance

Important Information

Read instructions fully before the installing this appliance.

1. This manual covers the operation of the MVHR control system only, it must therefore be read in conjunction with the relevant heat recovery unit Product Manual.
2. Installation of the appliance and accessories must be carried out by a qualified and suitable competent person and be carried out in clean, dry conditions where dust and humidity are at minimal levels.
3. All wiring must conform to current I.E.E. Wiring Regulations and all applicable standards and Building Regulations.
4. aura-t must be connected using the communication cable provided.
5. Control & communication cables should not be placed within 50mm or on the same metal cable tray as any 230V lighting or power cables.
6. Ensure all cable glands are fully tightened.
7. The unit must be stored in a clean and dry environment. Do not install the appliance in areas where the following may be present or occur;
 - Excessive oil or a grease laden atmosphere,
 - Corrosive or flammable gases, liquids or vapours,
 - Ambient temperatures above 40°C or below -5°C,
 - Humidity levels above 90% or is a wet environment.

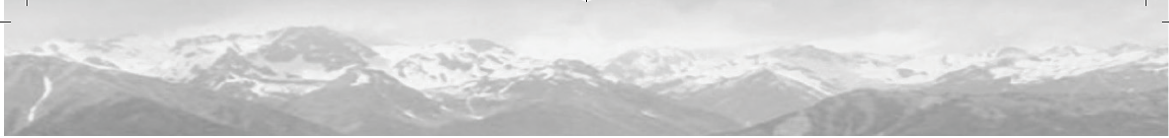

8. The appliance is not suitable for installation to the exterior of the dwelling.
9. This appliance can be used by children aged from 8 years and above and persons with reduced physical, sensory or mental capabilities or lack of experience and knowledge if they have been given supervision or instruction concerning use of the appliance in a safe way and understand the hazards involved.
10. Children should be supervised to ensure that they do not play with the appliance.
11. To avoid damaging the touch screen, do not operate it with sharp or hard objects; do not apply excessive fingertip pressure.
12. Do not use abrasive cleaners, waxes, solvents or alcohol based cleaning products; do not use paper towels for cleaning the aura-t.



Contents

Warnings, Safety information and Guidance

Important Information	2
-----------------------------	---

Product Overview

Description	5
Packaging Contents	5
Dimensions	5
Features	6
Speed Selection & Display	6
24 Hour Clock	6
Day of Week Display	6
Boost Overrun Timer	6
Internal Humidity Sensor	6
Filter Change Alert	6
Programmable Speeds	6
Boost Inhibit	6
Status Icons	6

User Interface

Menu Tabs	7
Run Mode	8
Status Icons	8
Other Icons	9

Installation

Location	12
Fixing	12
Wiring	13
Fan Commission	14
Controller Setup	16
Summer Bypass Setup	18
Passcode Enable / Disable	18
Switch Setup Menu	19

Maintenance

Cleaning Exterior	20
-------------------------	----

Appendix

aura-t Configurable Defaults	20
axco MVHR Defaults	22

Product Overview

Description

The aura-t is a programmable touch screen controller which monitors and displays the status of a BEAM MVHR unit. It allows the unit to be commissioned, and gives the user both manual and timed control of fan speeds. The aura-t is connected to the MVHR via a low voltage connection and can be sited remotely from the unit.

Packaging Contents

Inspect the unit when taking delivery. Check the unit for damage and that all accessories have been supplied.

Package supplied with:-

- 1 x aura-t controller.
- 1 x ~3m aura-t communication cable.
- 1 x Product Manual.

Any shortages or damage must be immediately reported to the supplier.

Dimensions

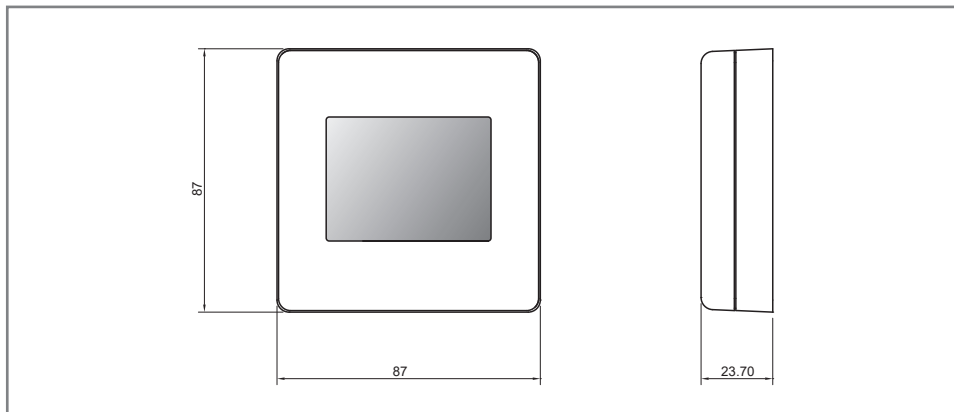

aura-t



Features

The following gives an outline description for each of the product features.

Speed Selection & Display

The unit speed can be manually selected via the on screen 1, 2, 3 & 4 buttons/ icons which are also used to display any automatically selected speed.

24 Hour Clock

The aura-t has a twenty four hour clock with a battery backup.

Day of Week Display

The aura-t displays the days of the week as numbers.

Boost Overrun Timer

A programmable timer that controls the time the MVHR remains at Boost Speed after all boost switches have been released.

Internal Humidity Sensor

The MVHR has a relative humidity (RH) sensor. The RH sensor can be programmed to switch the MVHR into Boost Speed.

Status Icons

The aura-t displays icons to indicate modes of operation in Real-time.

Filter Change Alert

The aura-t will display an alert after a specified time when the MVHR filters require changing. Filters should be changed yearly. Replacement filters available from:

www.beamcentralsystems.com

Programmable Speeds

The unit has 4 programmable speed settings, all speeds are variable between 14-100% and allow independent speed setting of both supply and extract ventilation rates

- Speed 1, Setback.
Reduced ventilation.
- Speed 2, Continuous.
Normal ventilation.
- Speed 3, Boost.
Increased ventilation
- Speed 4, SUMMERboost®.
Very high ventilation.

Boost Inhibit

Boost Inhibit is used to prevent the MVHR's speed increasing. Boost Inhibit is used in conjunction with a Timer event.



User Interface

The aura-t is operated via a LCD touchscreen. The screen is backlit, the backlight operates when the screen is touched.

Menu Tabs

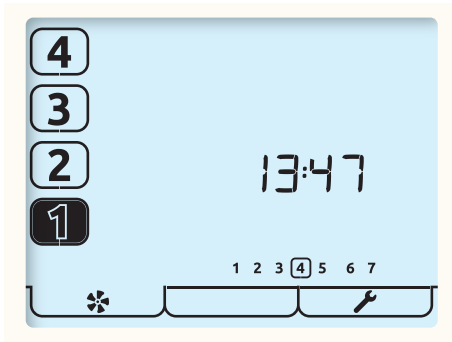
The aura-t screen has three interactive menu screens which are selected via tabs at the bottom of the touchscreen.



Tab			
Function	Monitor & Control Fan Commission	None	Setup
Name	Run Mode		Setup Mode
Description	Displays Fan Speed, Time, Day and Status. Gives access to Fan Speed Setup		Gives access to Time, Day, RH threshold, Overrun Timers, Summer Bypass, Passcode settings & Filter Reset. Switch Setup in a Sub-Menu.
If passcode is enabled enter 3333 to activate the above menus.			

Run Mode

The aura-t controls the MVHR unit's 4 programmable speed settings.

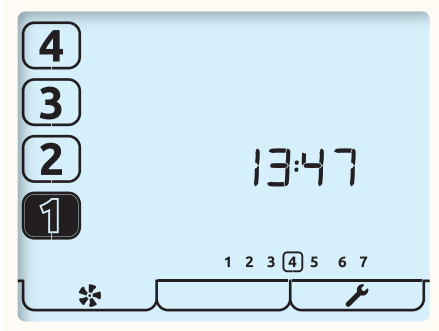

This is the Run Mode screen; use the number buttons to select the required fan speed.

1

Press and Hold the [1] or [2] button to enable boost Inhibit, the Padlock icon will display to indicate Boost inhibit is active.

2

Pressing and Holding either the [1] or [2] button again will disable Boost Inhibit.

The current running speed will be indicated by the corresponding number button being highlighted.

The time of day is also shown on this screen in 24 hour format along with the days of the week; the current day is ringed.

Status Icons

If the fan speed is being controlled by an external switch, a sensor or the timer this is indicated by an icon beneath the speed selection buttons being visible.

The icons are as follows:



An external switch is active and is holding the MVHR at the indicated speed.



The speed the MVHR is running at is being controlled by the internal humidity sensor or an external Proportional Input sensor

Other Icons

Other status icon that may be visible on the screen are listed below:



The filters need changing or cleaning, refer to the Settings Menu for details of how to reset the timer.



Frost Protection, if this icon is constantly lit the temperature outside is low and the speed of the MVHR Supply Fan has been reduced to prevent damage to the Heat Cell. If the Frost icon and backlight are flashing the indoor temperature is low and both fans will have stopped. Tap any of the fan speed number buttons to restart the fans. If the temperature is still too cold, Frost Protection will be activated.



Summer Bypass is in operation, air from outside is being supplied directly to the property without recovering heat from the Heat Cell. This is often accompanied by SUMMERboost®, both fans switch to Speed 4 to increase the rate fresh air is supplied to the property and stale hot air is extracted.

Press & Hold the [4] button to cancel SUMMERboost®.



The Boost Overrun timer is active and is holding the MVHR at Speed 3; this follows an external Boost switch being deactivated or if the internal Humidity sensor has put the unit into Boost and the Humidity has reduced below the set-point.



The padlock icon adjacent to the Speed 3 button and accompanying the timer icon indicates Boost Inhibit is active. The MVHR is being held at Speed 1 by the timer and will not respond to external Boost switches or the internal Humidity sensor; it is also not possible to manually increase the speed the MVHR's running speed. Proportional Input sensors are not affected.



The warning icon flashing at the bottom of the screen adjacent to the Fan icon indicates a fan failure has been detected; contact the installer. If very high temperatures are detected inside the MVHR, fan failure mode will be enabled to protect the MVHR from damage.

Installation

Location

The aura-t should be mounted in position convenient for the householder and where the supplied control cable will reach. As standard the aura-t is supplied with a 3m control cable. If a longer cable is required 0.75mm² 4 core cable should be used, to be supplied by your electrician.

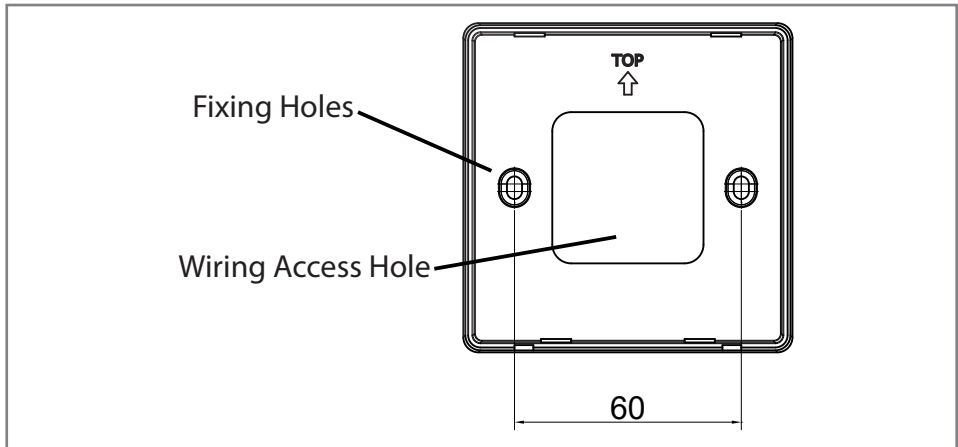

Connection to MVHR

Fixing

1. Un-clip the front of the aura-t case from the Back Plate.
2. Thread the control cable through the hole in the Back Plate.
3. Fix Back Plate .
4. Connect the communication cable, see Wiring section.
5. Clip the front of aura-t to the Back Plate.

Wiring

The aura-t's control cable may be supplied fitted with a plug in connector for connection to the MVHR, if the MVHR does not have a socket remove the plug and use the wiring diagrams below.

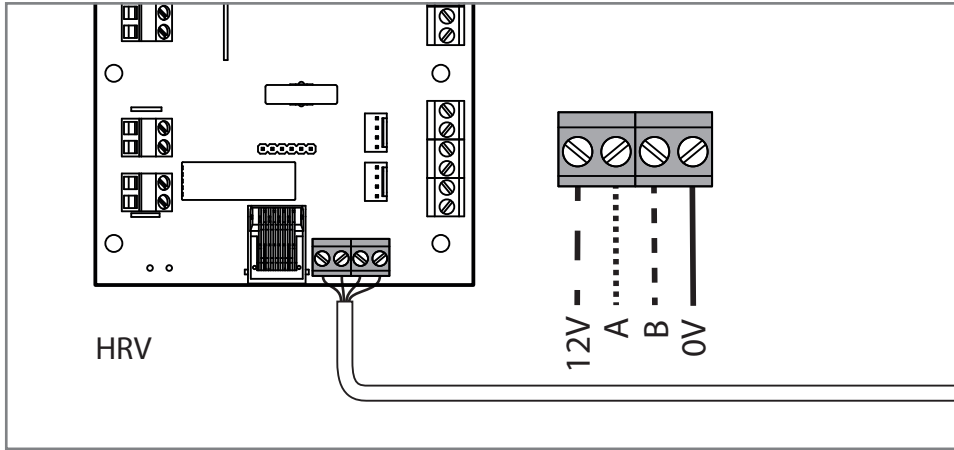

Connection to MVHR

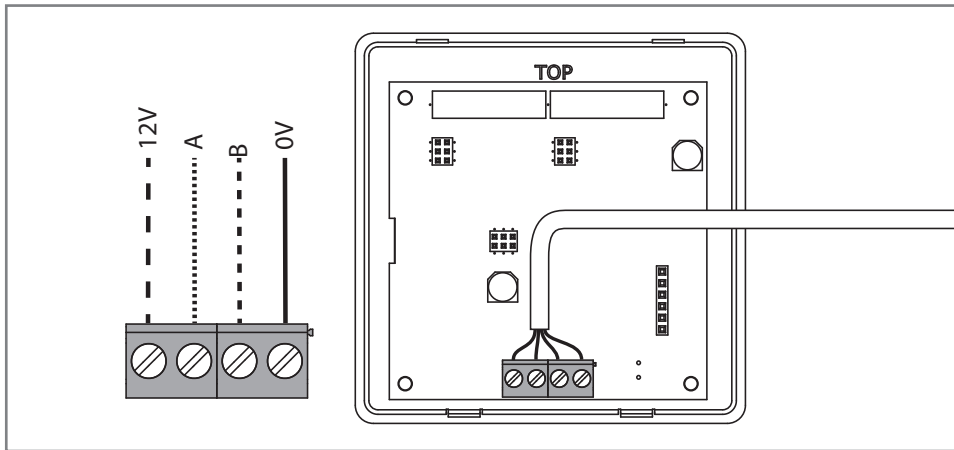

Connection to aura-t

Controller Setup

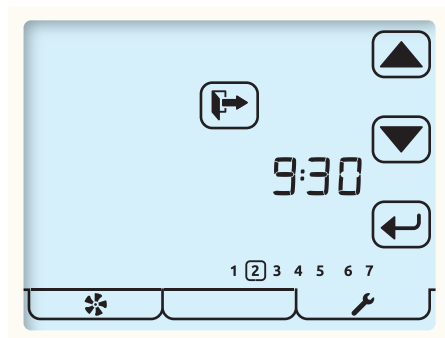

Enter key.



Exit Key.

 Tap the Setup Mode tab to enter the Setup Mode menu.

All the editable settings in the Controller Setup menu are accessed in the same way. Menu navigation is achieved by first Setting Selection and then Editing.

Setting Selection



- Arrow keys are used to select a setting, the setting will flash.



- Tapping the Enter key will allow the setting to be edited.



- Tap the Exit button to return to Run Mode.



Setting Editing



- Arrow keys are used to change setting value.



- Tapping the Enter key whilst editing will save and move to the next setting in the list.



The order in which editable settings are displayed is as follows.

6:30

1. Time (24 hour clock)

1 2 3 4 5 6 7 2. Day of week.



3. Humidity threshold



4. Kitchen Overrun timer.



5. Wet room Overrun timer.



6. Summer Bypass Setup.



7. Passcode Disable / Enable.



8. Filter Reset



If a filter change is required the reset ring will be flashing.
Tap the Enter key to reset or the Exit key.



If a filter change is not due but the filter timer requires
resetting press the Enter key twice.



Tap Exit key to return to Run Mode.

Summer Bypass Setup

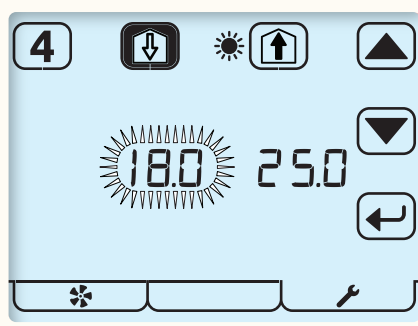

Use to adjust value up or down.



Enter key.



Supply



Extract

Use the Supply and Extract buttons to select which threshold is to be adjusted. Supply represents from atmosphere air temperature; Extract represents from dwelling air temperature.



Tap button[4] to enable / disable SUMMERboost.
Unfilled icon (shown) represents disabled.

Passcode Enable / Disable

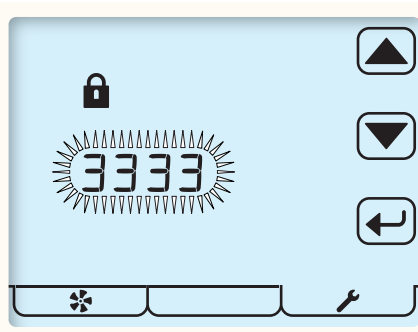

Tap Enter key to edit state.



Use to enable / disable Passcode.





---- indicates Passcode is disabled.
3 3 3 3 indicates Passcode is enabled.

Switch Setup Menu

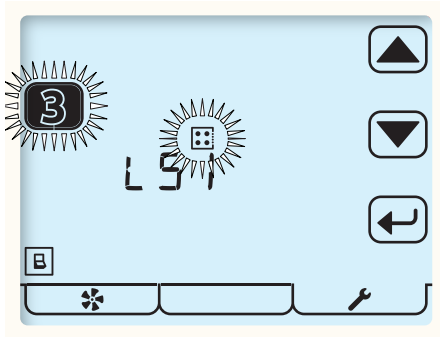
In this Sub-Menu of the Setup Menu the installer can configure the function of the MVHR unit's switch inputs S1, S2, S3, LS1 & LS2 (see MVHR Product Manual for details)



 Enter key.

 Exit Key.

 Press and Hold the Setup Mode tab to enter the Switch Setup Mode menu.*



Switch Setup menu active.

All switch inputs to the MVHR unit; S1, S2, S3, LS1 & LS2 can be assigned any of the following functions.



Kitchen Boost, Speed 3.



Wet Room, Boost, Speed 3.



Speed 1, Setback



SUMMERboost disable.



Speed 4

* If Passcode is enabled, access to the Switch Setup Menu is only available from the Time setup menu.

Maintenance

The aura-t is maintenance free.

Cleaning Exterior

For best results use a clean damp micro fibre cloth. Do not use abrasive cleaners, waxes, solvents or alcohol based cleaning products; do not use paper towels for cleaning the aura-t.

Appendix

aura-t Configurable Defaults

The table below details the default values and the range of available settings, plus any additional information about those settings the aura-t can configure. There is space available in the table where the installer should record all configuration settings.

Configurable Item		Range		Default	Configured	Additional information
		Min	Max			
Time		Any Time		00:00		24 hour clock.
Day of Week		1	7	1		Two groups, five week days & two weekend days.
Boost Overrun	Kitchen	0 mins	60 mins	15 mins		
	Wet Room	0 mins	60 mins	15 mins		
Boost Overrun timers are set independently for Kitchen and Wet Room inputs. Boost Overrun timers must be set greater than zero for any momentary switch to trigger boost. When using latching switches to initiate Speed 3, Boost, the Overrun timer will start when the latching switch is disengaged.						
Internal Humidity Boost (Set point)		30%	89%	70%		
Speed 1, Setback.	Supply	14%	100%	18%		
	Extract	14%	100%	18%		
Speed 2, Continuous.	Supply	14%	100%	40%		
	Extract	14%	100%	40%		
Speed 3, Boost.	Supply	14%	100%	70%		
	Extract	14%	100%	70%		



Configurable Item		Range		Default	Configured	Additional information
		Min	Max			
Speed 4, SUMMERboost®	Supply	14%	100%	100%		
	Extract	14%	100%	100%		
Summer Bypass	Extract	17°C	35°C	25°C		
	Supply	10°C	20°C	18°C		
<p>In order for the Summer Bypass to operate the temperatures of both the air being extracted from the property and supplied from outside must be above their individual thresholds. If the temperature of the Supply air is less than 1°C cooler than the Extracted air the Summer Bypass does not operate to prevent the warmer air being supplied directly to the property.</p>						
SUMMERboost®		Enabled	Disabled	Enabled		
<p>SUMMERboost® operates in conjunction with Summer Bypass and switches the fans to Speed 4. It can also be disabled by a latching switch if fitted.</p>						
Switch Inputs	SW1			Kitchen Boost		
	SW2			Wet Room Boost		
	SW3			SUMMERboost® Disable		
<p>Switch options are: Kitchen Boost, Wet Room Boost, Speed 1, Speed 4, SUMMERboost disable. When configured as Kitchen or Wet room Boost, the switch will use the associated Boost overrun and delay times for that room.</p>						
Live Switch Inputs	LS1			Kitchen Boost		
	LS2			Wet Room Boost		
<p>Live Switch options are: Kitchen Boost, Wetroom Boost. Live Switches also use the Boost overrun and delay times for the rooms they have been configured to.</p>						

Some control features documented in this manual may not be compatible with older BEAM MVHR units.

axco MVHR Defaults

The table below details MVHR settings and defaults, which that the aura-t CANNOT configure. During installation and commissioning they may be changed from the default values by an alternate BEAM controller. There is space available in the table where the installer should record configuration settings.

Configurable Item		Range		Default	Configured
		Min	Max		
Boost Delay Timer	Kitchen	0 mins	60 mins	0 mins	
	Wet Room	0 mins	60 mins	0 mins	
If the Boost Delay Timer is set greater than zero momentary switches will not switch the MVHR into Speed 3 Boost. When using latching switches the MVHR will not Boost until the Delay time has elapsed.					
Filter Change Interval		3 Months	24 Months	12 Months	
Summer Bypass Enable/Disable		Enabled	Disabled	Enabled	
Frost Protection Mode		Off	Reduce	Off	
Frost Protection Threshold		-2°C	11.5°C	2°C	
When Frost Protection is operating in Off Mode the Supply fan is switched off when the temperature measured by the sensor on the to atmosphere side of the heat cell drops below the Frost Protection Threshold. When operating in Reduce Mode the speed of the Supply Fan is gradually reduced when the temperature drops below the threshold. At 4°C below the threshold it is stopped.					
Duct Heater Enable/Disable		Enabled	Disabled	Disabled	
Duct Heater Mode		Frost	User	Frost	
Duct Heater Threshold		-4°C	16°C	4°C	
Duct Heater Hysteresis		1°C	10°C	1°C	
When operating in Frost Mode the Duct Heater uses the sensor on the to atmosphere side of the Heat Cell and switches on 2°C above the Frost Protection threshold. When operating in User Mode it uses the sensor on the from atmosphere side of the heat cell and the threshold and hysteresis detailed above. In both modes the Duct Heater will be switched off if the Supply fan speed drops below 22.5% PWM.					
Internal Humidity Boost				On	
RH Boost Overrun		1 min	60 mins	15 mins	
RH Boost Hysteresis		1%	10%	1%	
When the Humidity of the air being extracted from the property reaches the threshold configured by the aura-t the fans switch to Speed 3 Boost. They remain at Speed 3 until the Humidity has dropped below the threshold minus the hysteresis and the RH Boost Overrun time has elapsed.					



Configurable Item		Range		Default	Configured
		Min	Max		
Room Sensor 1 Enable/Disable		Enabled	Disabled	Disabled	
Sensor Type				%RH	
Lower threshold				60%	
Upper threshold				70%	
Room Sensor 2 Enable/Disable		Enabled	Disabled	Disabled	
Sensor Type				CO ₂	
Lower threshold				800PPM	
Upper threshold				1400PPM	
<p>If fitted, Room Sensors are used to provide Demand Control Ventilation based on the environmental parameter they are measuring. Below their lower threshold they have no effect on the ventilation rate; once the lower threshold is exceeded the fan speeds proportionally increase from Speed 2, Continuous until the upper threshold is reached when the fans will be running at Speed 3, Boost. In addition to the %RH and CO₂ sensor detailed above Air Quality and Temperature Room Sensors may be fitted. With any Room Sensor the range of Demand Control Ventilation will be dependant on the individual sensor's characteristics and the thresholds configured by the installer.</p>					



In the event of any queries please contact the system installer.

Ensure this booklet is passed to the householder once installation & commissioning of the ventilation system is complete.

This Product Manual must be kept in the Home Information Pack.

Installed by:



BEAM Vacuum & Ventilation
Opus Business Park
35 Aughrim Road
Magherafelt
BT45 6BB, NI

telephone [NI & UK] +44 (0)28 7963 2424
facsimile [NI & UK] +44 (0)28 7963 2425
telephone [ROI] +353 (0)1 833 0668

email info@beamcentralsystems.com
website www.beamcentralsystems.com